

HUSKY FOLDING 25

**FOR FOLDING
DOORS AND
ROOM DIVIDERS
TO 25KG**

For efficient and easy-to-use light folding doors, neatly stacking at one side and without floor guides for an uninterrupted run of carpet. For larger openings, a floor guide channel should be included. If doors are required to stack at both sides additional pivots are required. Soffit fixing only is available.

KITS

Kits HF25/12 and HF25/24 contain: top and bottom pivots for fixing into end panel; 4-wheeled adjustable nylon hangers; hinges; screws; fixing instructions and steel track no. 280.

FITTING PACKS

2 and 4 leaf fitting packs contain all the components contained in the kits except the track. Order also track no. 280 or aluminium section track no. 280A.

OPTIONAL EXTRAS

Optional extras include: set of 5 brackets no. 2815; guide no. 106HF/94; channel no. 94X; flush-bolt no. 333; flushpull no. 400 (see pp 52-57 for full product description). Bulk component packs are also available.

INSTALLATION NOTES

(also see drawing)

For panels with maximum single weight 25kg, maximum dimensions 600mm wide x 2400mm high and thickness 20-40mm; 12 panels (6 each side) maximum. For panels in excess of 15kg, 450mm wide or for 4 or 6 panel units, a floor guide channel

For opening widths to	No. panels	Kit no.	Channel required
1200mm	2	HF25/12	1 x 1.2m
2400mm	4	HF25/24	1 x 2.4m
Max leaf size		2400 x 600 x 40mm	
Max leaf weight		25kg	

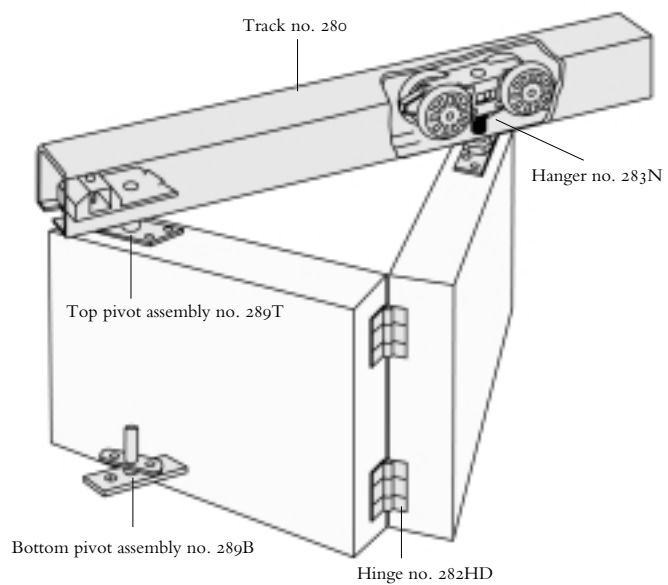

SOFFIT FIXED

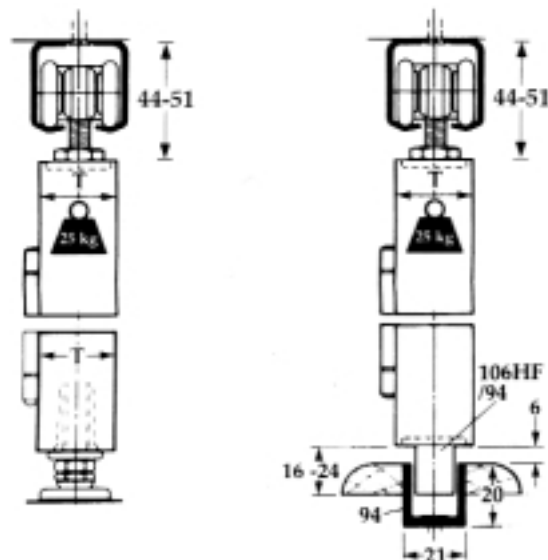

Optional guide channel

All dimensions in mm