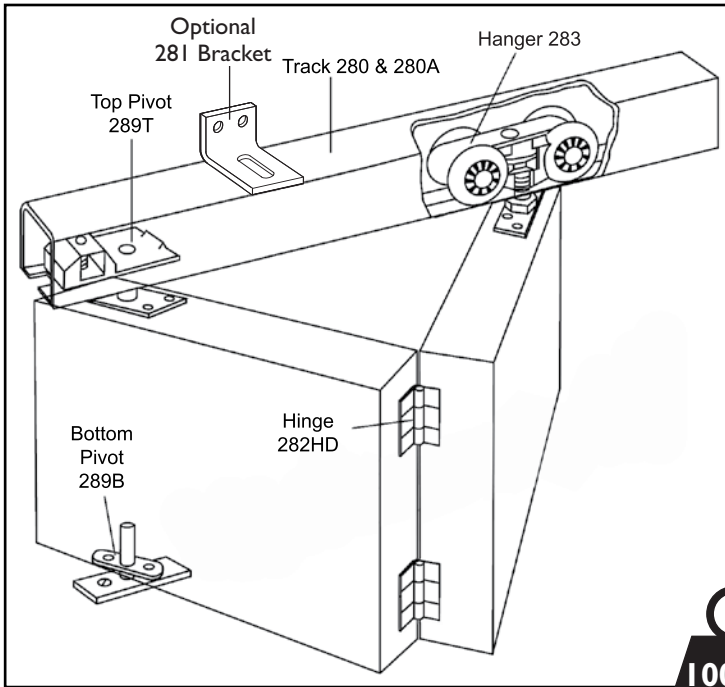

Folding 100 Series Installation Instructions

800-824-3018 • www.pemko.com

Folding Doors and Room Dividers - Up to 100 lbs / Up to 24" Wide x 96" Tall

Manufactured by

HENDERSON

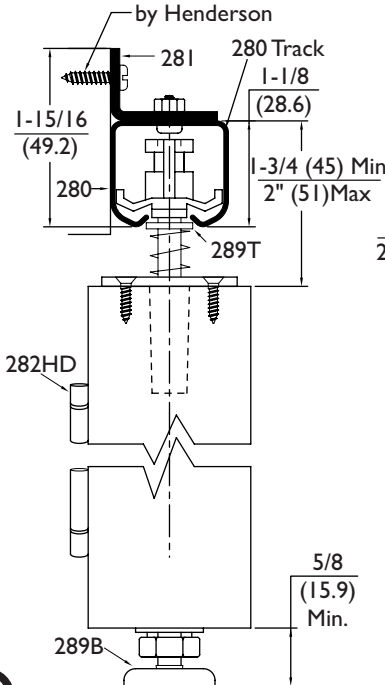
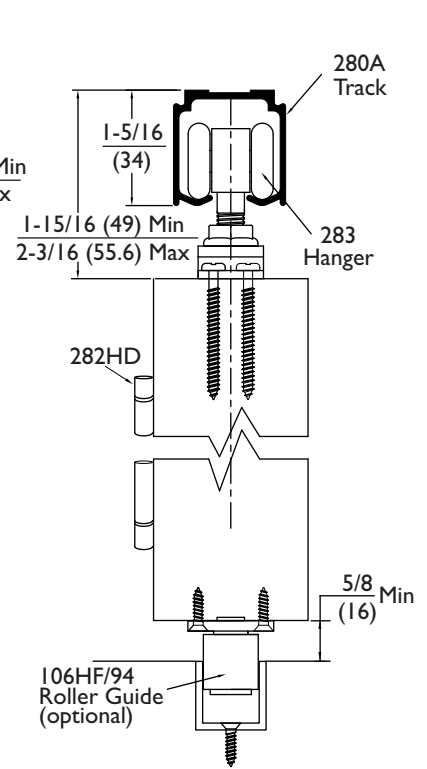
100 lbs
max door weight

280 Side Wall Mounted

280A Overhead Mounted

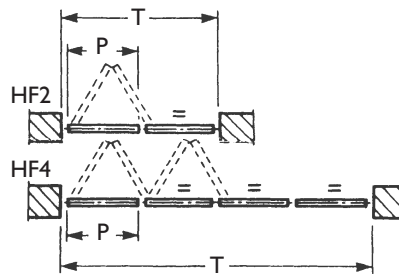
STANDARD KIT SIZES

Part Number	Material	# of Panels	Track Length
HF2/100A/2	Aluminum	2	24"
HF2/100A/2'6	Aluminum	2	30"
HF2/100A/3	Aluminum	2	36"
HF2/100A/4	Aluminum	2	48"
HF4/100A/4	Aluminum	4	48"
HF4/100A/5	Aluminum	4	60"
HF4/100A/6	Aluminum	4	72"
HF4/100A/8	Aluminum	4	96"
HF2/100/4*	Steel	2	48"
HF4/100/8*	Steel	4	96"

Steel kits include the same components as above, except track is 1 ea 280 galvanized steel.

 P = Number of Panel
T = Track Length

NOTE: Allow 1/4" (6.4) clearance at pivot jambs and 1/8" (3.2) in between hinged doors if hinges are semi mortised. Allow 3/16" (4.8) between hinged doors if hinges are surface mounted. Allow 1/8" (3.2) between doors meeting in the center of the opening on HF4 kits and allow 1/8" (3.2) between wall and end panel on HF2 kits.

Two Panel: HF2/100A Kits Include:

- 1 ea 280(A) Mill Finished Aluminum Track
- 1 ea 283 Hanger
- 1 ea 289T Top Pivot
- 1 ea 289B Bottom Pivot
- 3 ea 282HD Hinges
- 1 ea 106HF/94 Roller Guide
- 1 ea 94A Aluminum Guide Channel
- 1 ea Adjusting Wrench and Mounting Hardware
- 281 Mounting Bracket for Side Wall Mounting, optional

Four Panel: HF4/100A Kits Include:

- 1 ea 280(A) Mill Finished Aluminum Track
- 2 ea 283 Hangers
- 2 ea 289T Top Pivots
- 2 ea 289B Bottom Pivots
- 6 ea 282HD Hinges
- 2 ea 106HF/94 Roller Guide
- 1 ea 94A Aluminum Guide Channel
- 1 ea Adjusting Wrench and Mounting Hardware
- 281 Mounting Brackets for Side Wall Mounting, optional

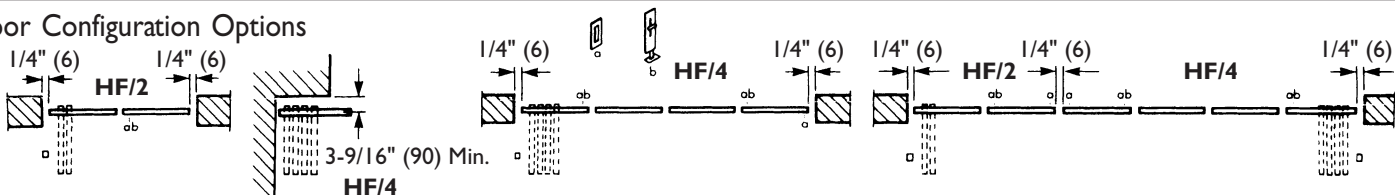
Door Configuration Options

INSTALLATION INSTRUCTIONS

1 Position and secure pivot and hanger apron plates.

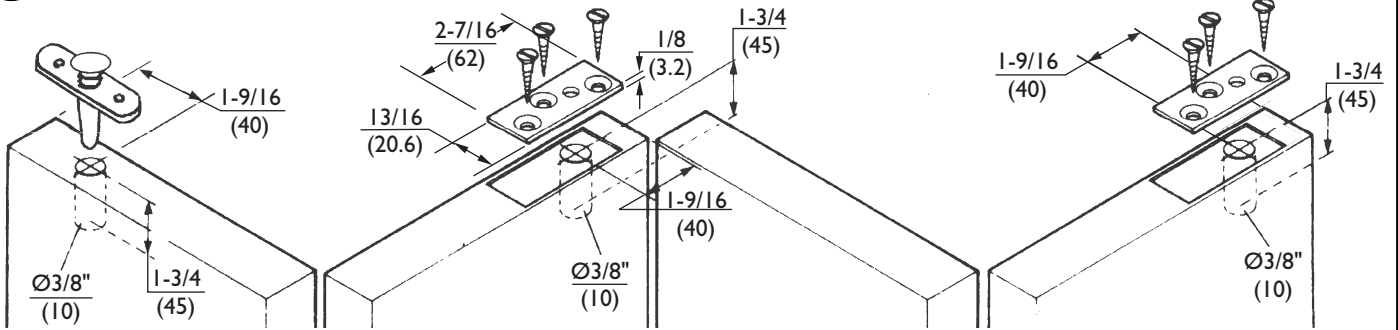

2 Fit bottom pivot assembly.

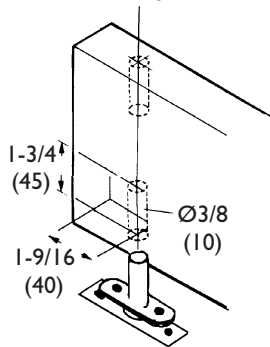

3 Attach hanger to apron plate(s) and bottom guide (if applicable).

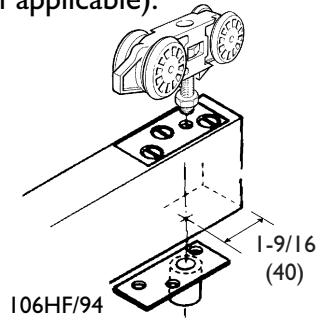

4 Position & secure hinges.

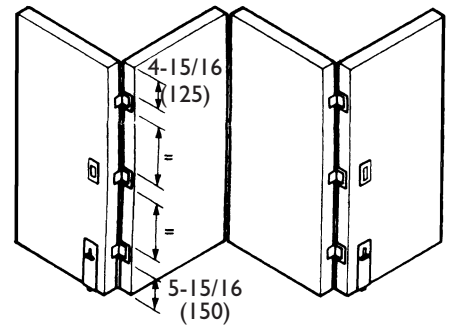

5 Cut track to size.

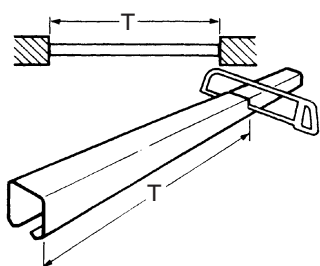

6 Position & secure top bearing plate.

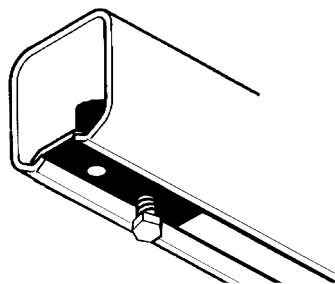

7 Face & Soffit Fix Options

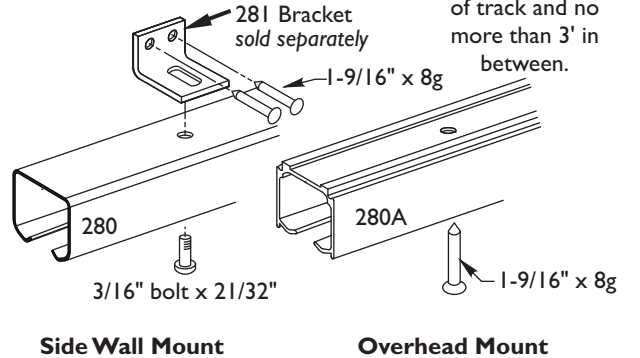

8 Slide doors onto track.

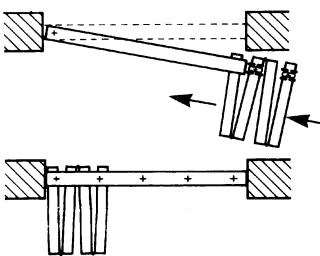

9 Locate & secure bottom pivot plate.

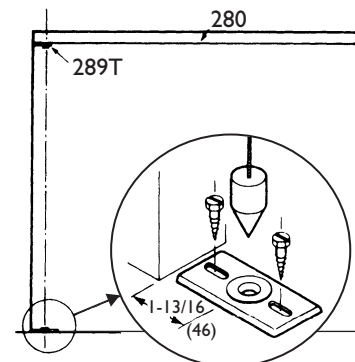

10 Adjust door height.

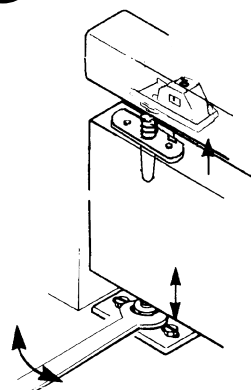

11 Align doors.

