

# SofStop™ Pocket Insert Kit

**CS TrackSystems** are an innovative range of track systems designed for a multitude of sliding doorway applications.

The **CS SofStop** pocket door kit is a smooth running, soft closing system designed specifically for pocket doors.

Engineered to stop doors up to 80kg (176lb), the CS SofStop is a must-have wherever quiet and safety are priorities. This system is the ultimate in style and sophistication.



*Pocket door with CS SofStop and CL400 Magnetic handle.*



*CS SofStop track and carriage.*

# SofStop™ Pocket Insert Kit

## Technical Information

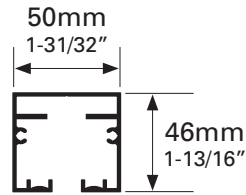

<b>Finish:</b>	Clear anodized
<b>Min Door Width:</b>	710mm 2'4"
<b>Max Door Weight:</b>	80kg 176lb
<b>Section Height:</b>	46mm 1-13/16"
<b>Section Width:</b>	50mm 1-31/32"
<b>Brush Seals Available:</b>	No
<b>Carriage Pack:</b>	15 / 35 / 80kg 33 / 77 / 176lb

## Design Features & Options

- Heavy duty one-piece extruded aluminum track.
- Minimal clearance means carriages/wheels cannot jump off track or jam.
- Large diameter wheels with precision ground bearings make for smooth running.
- CarriSnap™** quick release system allows the door to be removed easily from track; no need to unscrew anything and lose door height adjustment.
- Less controlled effort is required to close the door.
- Available as Single and Bi-Parting (double) units
- Suitable for areas where quiet is required, such as bedrooms, offices and patient rooms.
- High quality soft close mechanism has been independently tested to 100,000 cycles.
- SofStop mechanism is engineered to stop doors up to 80kg (176lb). A small amount of force is necessary to open the door.
- Best operating temperature: 10°C to 40°C (50°F to 104°F).
- Available in 6' or 8' lengths. Minimum recommended door width 710mm (2'4").

## Suggested Assembly Detail

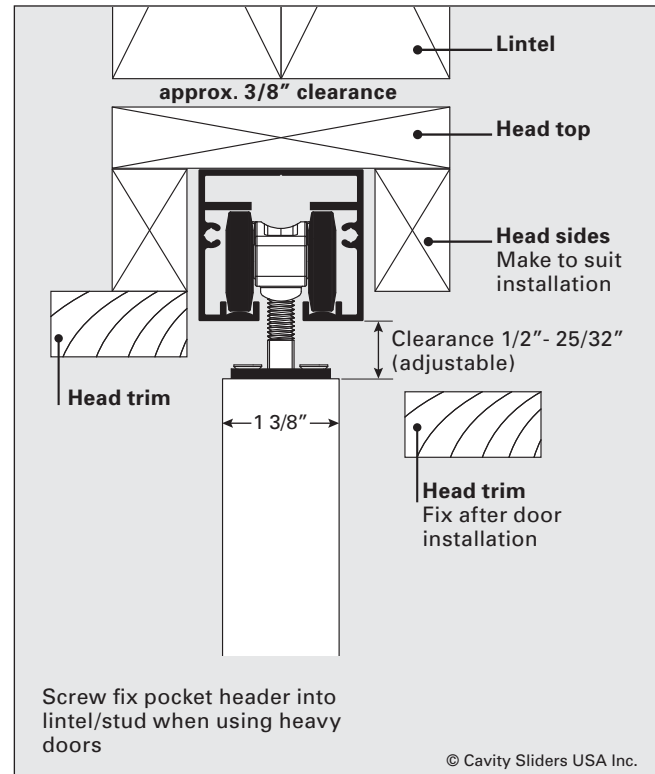

## Door Weight Options

SofStop Model	Door Type
<b>15kg</b> <b>0 - 15 kg</b> (0 - 33 lb)	Typically standard sized hollow core doors
<b>35kg</b> <b>15 - 35 kg</b> (33 - 77 lb)	Steel reinforced or solid core doors
<b>80kg</b> <b>35 - 80 kg</b> (77 - 176 lb)	Over sized, glazed timber or aluminum doors

## Pack Components

- CS SofStop Track (available in 6' and 8' pre-cut lengths)
- CS SofStop soft close mechanism and wheel pack (Single or Bi-Parting)
- T-Guide, fixing screws, adjusting wrench, track stops and installation instructions



## How to Order

1. **Specify track length** (available in 6' and 8' pre-cut lengths)
2. **Specify door weight** (see options on left)

© All copyright and other property in this document is reserved by Cavity Sliders USA Inc. Details and specifications are subject to change without notice. Whilst all care is taken to ensure the accuracy of all information, no responsibility will be accepted for any errors or omissions. CS SofStop™ (O.D. 2011). Patent pending. 60969 - 10.2014

[www.cavitysliders.com](http://www.cavitysliders.com)

High quality  
New Zealand made  
products



T (888) 466 0030  
F (310) 769 5824  
E [info@cavilock.com](mailto:info@cavilock.com)

Cavity Sliders USA Inc.

PO Box 1392  
Culver City  
CA 90232

Another quality product from:

**CavitySliders™**  
High Quality Sliding Door Hardware