

Step 4

With the actuator in place, be sure that the peak is not rubbing against the back side of the track. See figure (a).

Once your location is established simply use the screws to mount it onto the top of your door. See figure (b).

Installation is complete!

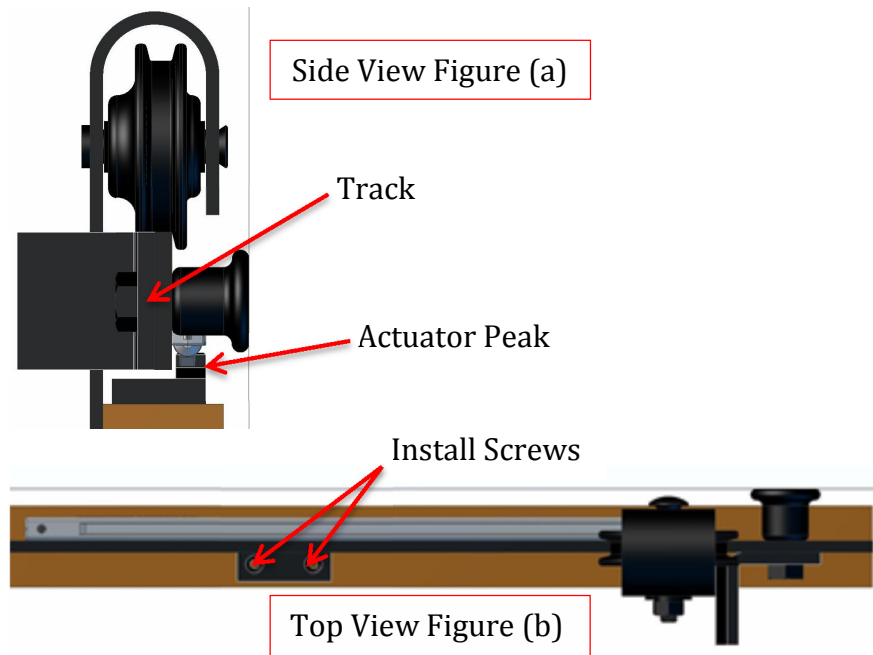

Thank you for choosing
Leatherneck Hardware for your
specialty sliding door needs.



1017 Bahls Street
Danville, IL 61832
info@doorhdwe.com
www.doorhdwe.com
888-442-4572

FLAT TRACK
BY LEATHERNECK HARDWARE

FLAT TRACK
BY LEATHERNECK HARDWARE

Close-Ease

Quick Reference
Installation Guide

For Maximum 150 lb. door &
can be used for both ends of track



info@doorhdwe.com
www.doorhdwe.com

Step 1

The Close-Ease system requires a standard spacing of 1/2" from top of door to bottom of track. Spacing greater than 1/2" will require shims so the actuator can properly function. These are not included in the kit.

To mount the closer, first place the closer up against the face of the track to visualize where the holes will be located before you start drilling. Be sure you have 15" available between the door stop and the spacer to mount the closer.

Locate hole (a) 21/32" from the bottom of the track and far enough away from the Stop that it doesn't interfere. Using a #29 bit, drill thru the track. Be careful not to puncture your wall. You can place a wooden block behind the track to protect the wall.

Once the hole (a) is drilled, measure 13 27/32" away from the hole(a) and 21/32" from the bottom of the track to position hole (b). Drill the second hole, then tap both holes for #8-32 thread.

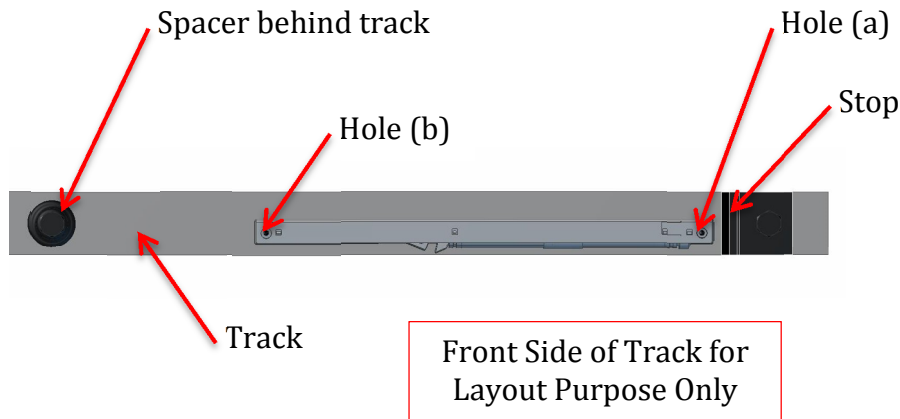

Step 2

After the holes are drilled, place the closer on the inside of the track. Be sure that the piston is closest to the side the stop is on and the catch is facing downward. Use the fasteners that are provided to mount the closer to the inside of the track.



Step 3

Next you will need to locate the actuator that comes with the closer. To do this, simply slide the door into the closed position and place the actuator on top of your door with the peak placed into the catch of the closer. Be sure the closer is in the engaged position as shown below.

